

# 1 PRODUCT WORKING PRINCIPLE

## 1.1 filtration process

under the action of the fan, the dust produced by this equipment enters the dust collector through the dust collector. First hit the spoiler in the middle of the inlet, the body into the spoiler from the role of the flow, so that the flow rate slower. Due to the gravity sedimentation, the coarse dust particles in the gas directly fall into the ash hopper and play the role of pre-dust removal. After the fine-grained and low-density dust particles enter the filter chamber, through the combined effects of Brownian diffusion and sieve filtration, the dust is adsorbed on the outer surface of the filter material. The purified clean gas enters into the upper clean air chamber through the filtering Jane, and is collected by the exhaust fan and discharged into the chimney.

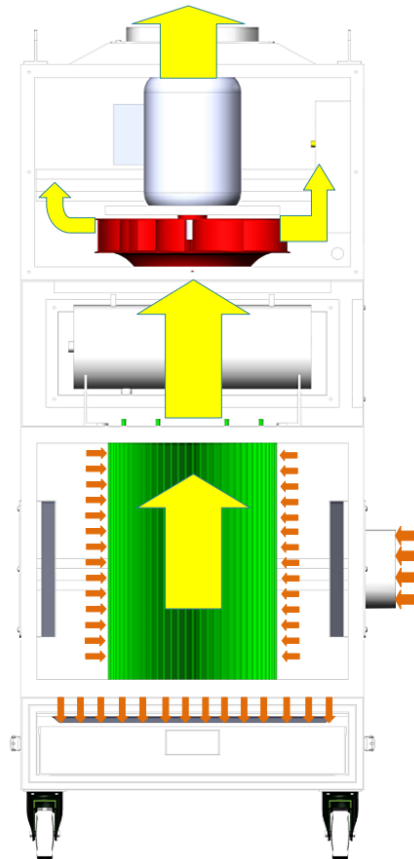

## 1.2 PNEUMATIC PULSE BACKBLOW CLEANING PROCESS

Pneumatic pulse backblow system is composed of cylinder, electromagnetic pulse valve, PLC controller and compressed air. End of the pulse valve is connected to the compressed air storage cylinder and

the other end is connected to the injection pipe. An exhaust valve is installed on the cover and the exhaust valve is controlled by a PLC controller.

When there is no signal from the PLC controller, the movable baffle of the exhaust valve is in the position of closed vent. When the program controller sends out a signal, the movable baffle opens and the compressed air in the storage cylinder is quickly released. Then the corrugated film inside the exhaust valve is pressed in the opposite direction. The air injection port opens and the compressed air enters the filter cylinder through the pulse valve

Spray to remove dust. When the signal disappears, the movable baffle returns to the original position of the closed exhaust valve, the corrugated film closes the air jet again, and the injection stops automatically.

Each time spray blowing ash in 0.1 ~ 0.3S or so to complete, is the moment the high-pressure air played a good ash cleaning effect. The air enters the filter cylinder at a high flow rate, which causes the filter cylinder to expand rapidly and causes an impact vibration, so that the dust attached to the filter cylinder is shaken off, and the dust adsorbed on the filter material surface is shaken off to the dust collector under the action of airflow. The pulse injection pressure is 0.4 ~ 0.6mpa, and the air supply must be kept constant during operation.

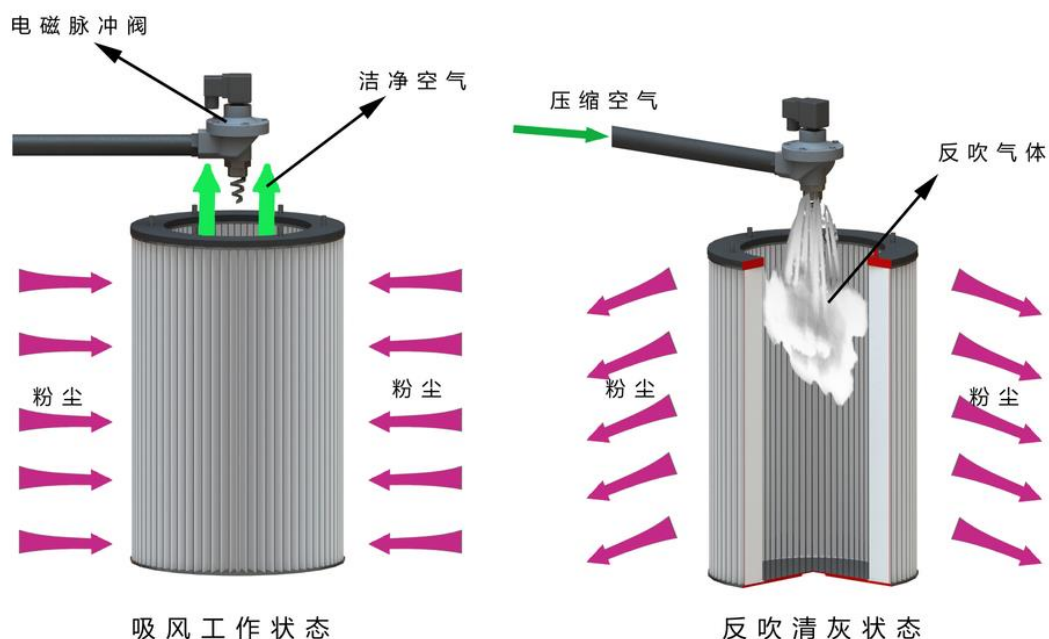



## 2 Product structure characteristics

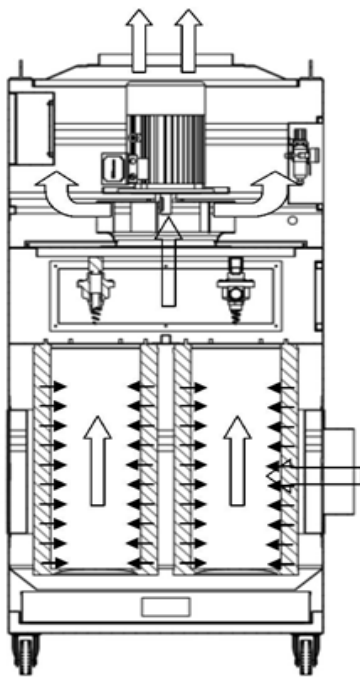

Vacuuming process

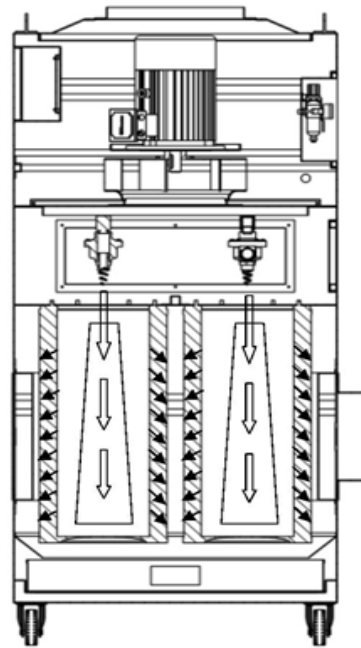

back flushing

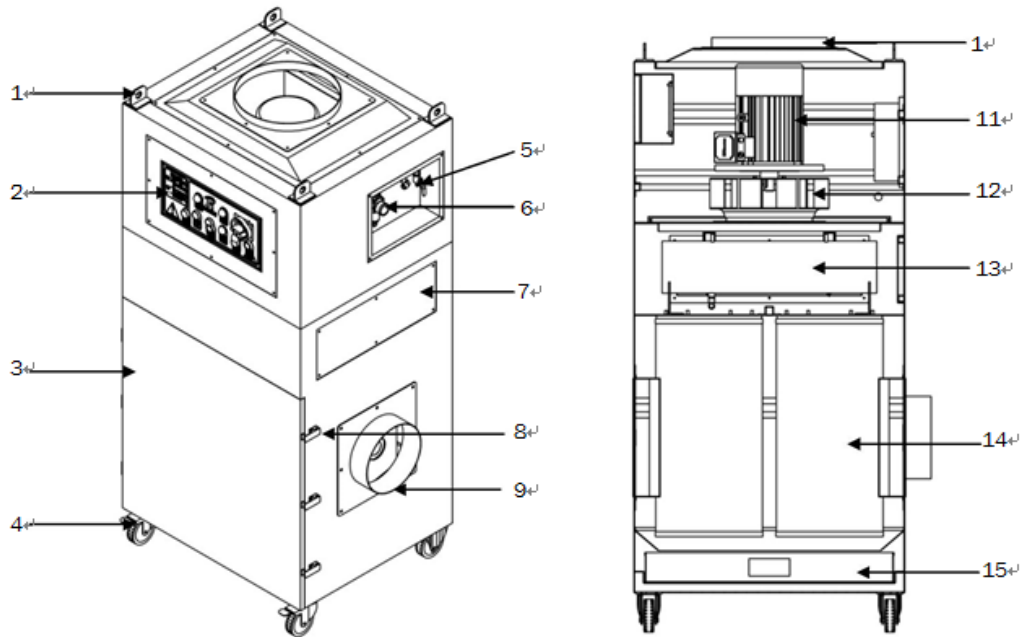

1. hanging structure
2. explosion-proof, electric control panel
3. door panel
4. PU universal casters (Fuma casters)
5. gas storage drain valve
6. oil moisture Yu Teng (pressure fine air inlet)
7. maintenance panel
8. adjustable buckle into
9. air inlet
10. top tuyere
11. explosion-proof motor
12. wind wheel
13. gas River blowback
14. anti-static filtering
15. collecting box

## 2.1 fans

The power unit of the fan is composed of a motor and a customized centrifugal fan. The centrifugal fan uses the backward type to leave

## 2.2 motor

The motor adopts domestic high-quality explosion-proof smoke-proof motor with high efficiency. The motor protection grade meets the requirements of IP54 protection grade in IEC 60034-5 standard, and the energy efficiency grade reaches GB18613-2012 provides for three levels of energy consumption.

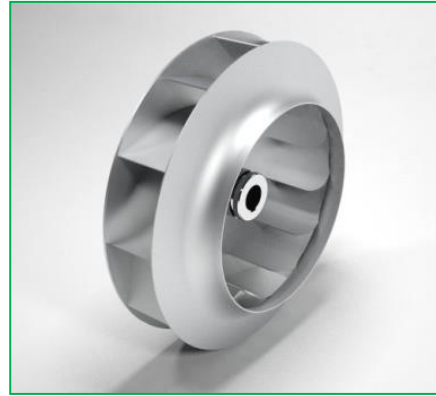
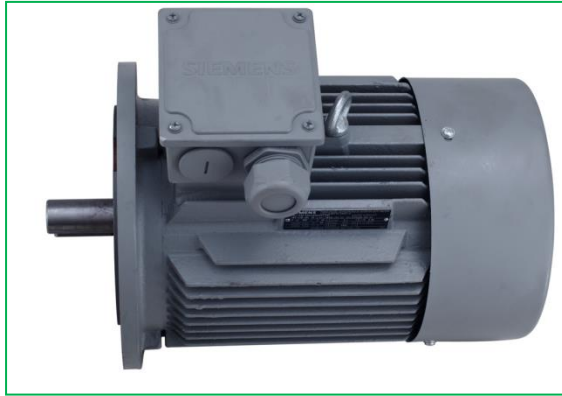

## 2.3 cartridge

Vertical installation of the filter cartridge of the filter unit, choose imported coated filter Jane (according to customer site conditions choose different filter); enkanThe furrow filter design increases the filtration area, and the membrane covering treatment makes the dust filtration efficiency above 0.3 um reach over 99%.



**Physical Properties of "NION" Polyester Spunbond**  
NION无纺布过滤材料物性参数

Type : N260ESDAL (型号)

**Features and Benefits (特点)**

- The Basic Spunbond From Toray Astar (日本TORAY进口基本)
- Superior mechanical strength and durability (良好的机械耐受性能)

**Physical properties and test method**

	Properties	Test Method
Weight (克重)	(g/sgm)	265
Thickness (厚度)	(mm)	0.62
Tensile Strength (抗拉强度)	MD (纵向) (N/50mm)	1160
	CD (横向) (N/50mm)	700
Elongation (延伸率)	MD (%)	39
	CD (%)	36
Mullen Burst (破裂强度)	(kPa)	2850
Gurley Stiffness @2.5inch-MD (mN)		31
Air permeability (透气量)	(cc/cm <sup>2</sup> /sec)	8
Collection Efficiency (%) (过滤效率)	0.3-0.5µm	48
	0.5-1.0µm	52
	1.0-2.0µm	86
	2.0-5.0µm	99
Pressure Drop (压差)	(Pa)	50 @32L/Min
Continuous Service Temperature (工作温度)	(°C)	120
Surface Resistivity (Average) (表面电阻值)	(Ω)	<10 <sup>8</sup> AL-plate (铝靶)

\*These data are only standard data not guarantee data.

## 2.4 pulse blowback system

It adopts the best filtering and cleaning technology so far, automatic pulse reverse blowing and special spiral injection technology. Kiyoshi The grey area covers the whole surface of the filter tube, and there is no blind area for cleaning.

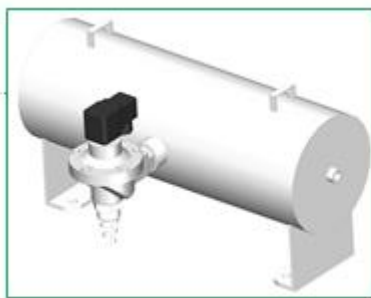

## 2.5 dust recovery unit

Dust collection box adopts drawer type structure. When the door is opened after the dust accumulates, the dust collection box can be pulled out for dust cleaning, and then the dust collection box can be sent. Convenient, quick and practical.



## 2.5 electronic components

Control unit circuit design power master switch, there is thermal overload, lack of equal phase sequence protection work cap, pulse reverse blow system aloneEstablish control, internal communication contact. Thermal overload and other major electronic components are deep with Schneider brand electrical components.All electric control components on the explosion-proof electrical box, explosion-proof electrical box such as barrier suction.



## 3 Equipment operation



- 1、 After the power supply is switched on, the red main switch of the power supply is turned on, the power indicator (red) is switched on, and the equipment is electrified;
- 2, Press the start button (green), running lights (green) light, electric motor start, fan operation;
- 3, Press the stop button (red), the running indicator (green) goes out, the motor stops running, the fan stops;
- 4、 Press the ash-cleaning switch, the green indicator of the metal self-locking switch turns on, and the pulse controller works electrically. Press again Under the self-locking switch, green lights go out, the pulse controller to stop working.

### **Special attention:**

- 1、 When the dust collector starts to work, the fan should be turned on and then the automatic dust cleaning is started.
- 2、The collector should be off-line cleaned at least twice a day: turn off the dust collectorfan (press stop button) and continue to turn on the dust removal function. Each off-line ash cleaning lasts more than 30 minutes, and timely clean up the collection box dust. Line cleaning: as the dust collector in operation is negative pressure on the surface of the filter cylinder, back blowing part of the dust, especially small Dust particles will be re-adsorbed on the filter surface, so must be off-line cleaning: stop the fan, but do not turn off the power and gas Source, continue to open the ash removal operation.

### **3.2 Ash unloading operation**

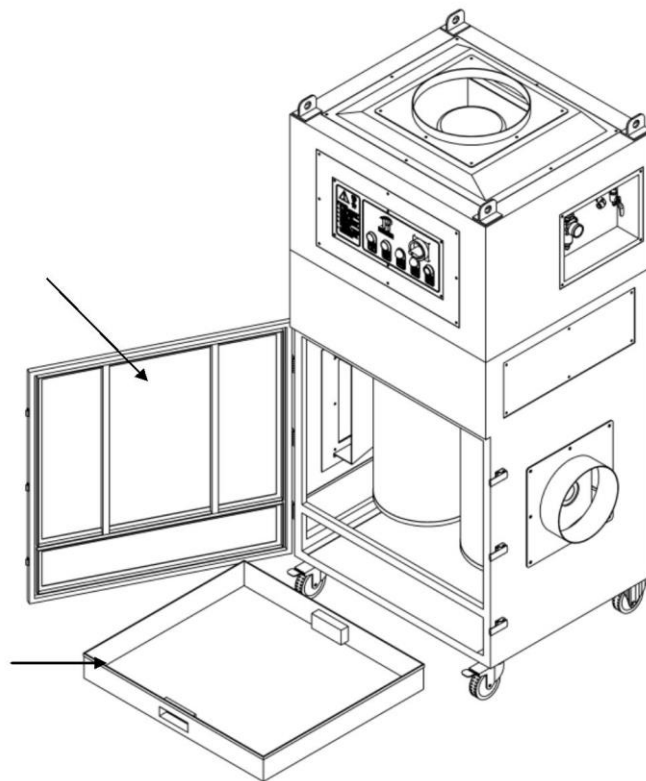

1. open the door
2. extract the dust collector to remove the collected dust
3. return the dust collector and close the door

### 3.3 cartridge replacement operation



Points to note for replacements:

Replacement of filter cartridge should be considered if the air flow rate is not enough or the use time is more than 8000 hours.

All filters need to be replaced at the same time.

When changing, pay attention to keep the meter ring clean and quiet, not percussion, handle lightly.

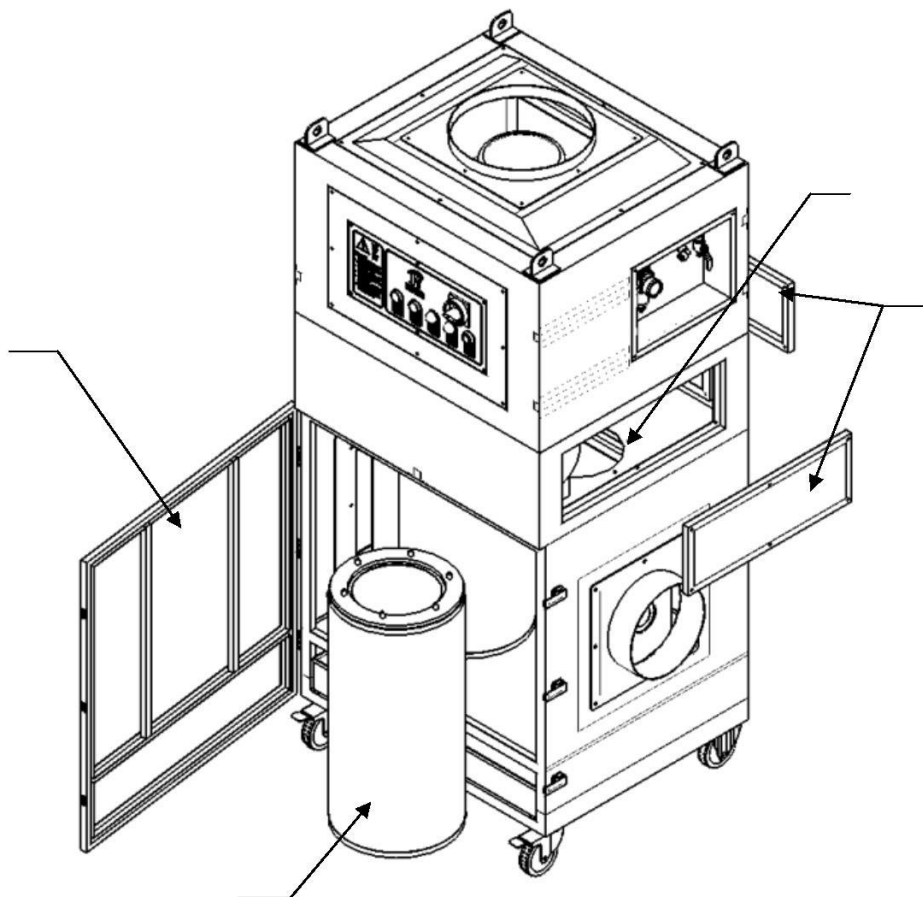

- 1 Remove and open the door panel.
- 2 unscrew the nut of the filter element to be replaced;
- 3 put on a new cartridge, fixed with nuts, the installation of maintenance board, close the door, replacement is completed.



### 3.4 clean-up operation of oil-water separator



1



2

1. Check the oil-water separator regularly, if the amount of water exceeds half of the container, clean up operation should be carried out, such as step 2.

2. as shown, the bottom of the oil-water separator is provided with a water outlet, and the water in the container can be cleaned by pressing the water outlet upwards.

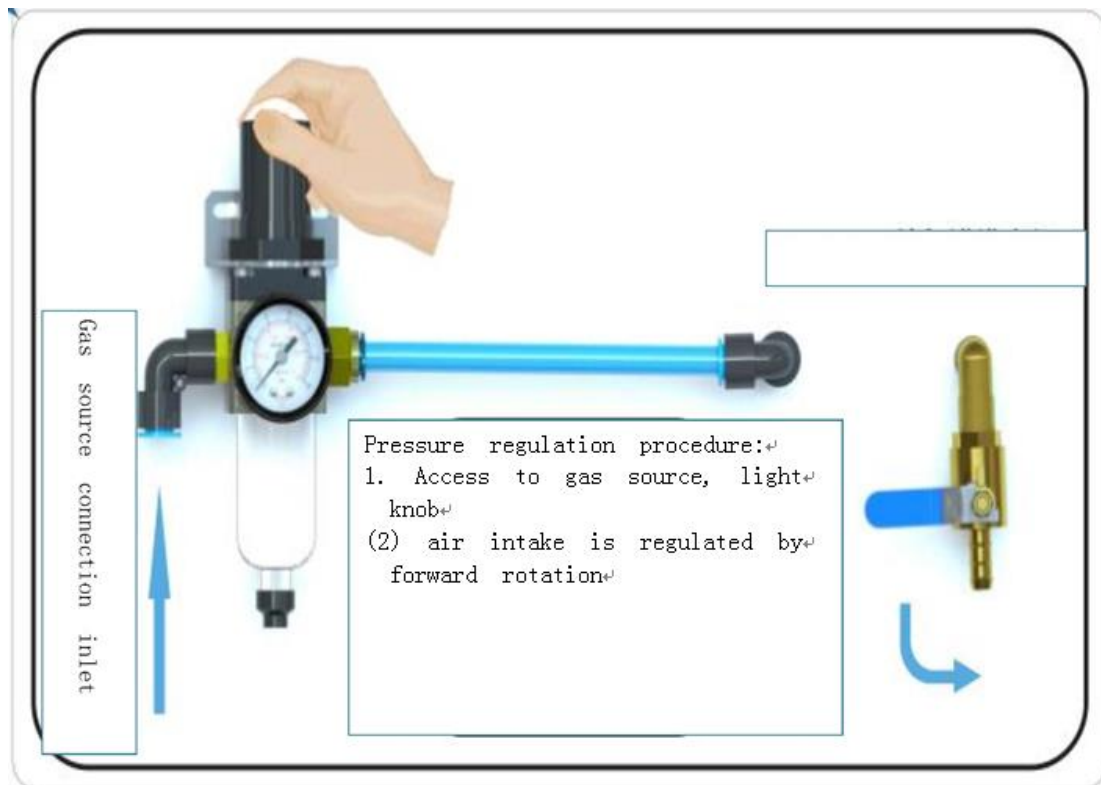

## 4 daily maintenance and repair of equipment

### 4.1 daily maintenance

- (1) in the operation of the equipment, special personnel shall be assigned to manage it and keep a good record of the work.
- (2) special personnel should be assigned to operate and inspect the dust remover and electric control equipment, and the operators must have a comprehensive grasp of the properties of the dust remover. Construct and operate rules, deal with problems in time to ensure the normal operation of the system.
- (3) the gas storage tank and the oil-water separator shall be drained once every shift, and the oil-water separator shall be cleaned every 1-2 months.
- (4) if the electromagnetic pulse valve failure. Should be promptly ruled out, such as internal impurities, moisture. Clean-up should be carried out. If the diaphragm is damaged should Change it in time.
- (5) periodic measurement of process parameters, such as flow, temperature, pressure, etc, found abnormal, should find the cause and timely treatment.
- (6) regularly check the working conditions of the gas path system and ash discharge system, and remove any abnormality in time.
- (7) when starting the machine, first connect the compressed air to the gas storage tank. Switch on the power to the controller. Start the ash removal device if it is still in the system for other equipment, start the downstream equipment first.
- (8) during shutdown, after the process system is stopped, the dust remover and the induced draft fan shall continue to work without load for a period of time to remove the installation for the moisture and dust in the equipment, it must be noted that the dust remover must be repeatedly cleaned when it stops working

(available manual cleaning) remove dust from the filter cartridge to prevent clogging of the cartridge due to moisture.

## 4.2 fault finding and troubleshooting

Fault characteristics	Cause of failure	Exclusion method
Duster does not work	Phase sequence connection	Swap the power cord L1 and L2
	Factory voltage fluctuates too much, under or over voltage	Negotiate and resolve within the factory
	The thermal overload protector is disconnected due to excessive current	Detect motor operation, may be hot over cut open
Abnormal running resistance	Flue gas condensation dust blocking filter	Plugging air leakage and increasing flue gas temperature
	Pulse valve does not work	Clean or replace pulse valve
	Compressed air source	Check oil-water separator pressure

	pressure is too low	and compressor
	Process system does not work	Back to work
Pulse valve does not work	Power failure or ash removal controller failure	Restore power supply, repair ash removal controller
	There's debris in the pulse valve.	Carefully clean pulse valve
	Solenoid valve coil burned out	Replace solenoid valve
	Compressed air pressure is too low	Check air system and compressor
Insufficient suction	Vacuum hose clogged or broken	Clean up or replace
	Check whether the straight and reverse blowing function is normal	Check that the trachea is properly connected and that the pulse controller is working
	Filter plug	Clean or replace filter cartridge
Excessive emission concentration	Incorrect installation of filter cartridge and bag	Reinstall and adjust filter bag position
	Filter Jane / bag break	Replace filter Jane / bag

	First use after replacing cartridge	Continue for about 15 minutes
--	--	-------------------------------